

MUGNAINI

— SINCE 1989 —

Mugnaini Series

MODEL: 160 x 120 PA
BUILT-IN ENCLOSURE

COMMERCIAL WOOD FIRED OVEN

CLEARANCES:

Install the oven with a minimum 1 inch clearance on sides and back to combustible construction. Consult the manual for enclosure instructions.

VENTING:

The oven can be vented in two methods:

1. Direct vent using 8 inch chimney pipe listed to UL 103 HT and installed per UL 737.
2. Indirect vent using a Type 1 hood system installed per UL 2162.

SHELF:

Stainless steel shelf bolts to oven. Shelf to be covered with non-combustible material provided by installer.

WEIGHT: 3700 lb.

UTILITIES:

No electricity or gas required.

NOTE:

The oven should be installed in accordance with all relevant local and national codes and in a manner acceptable to the authority having jurisdiction.

Progressive changes in technology and product development may necessitate changes to specifications without notice.

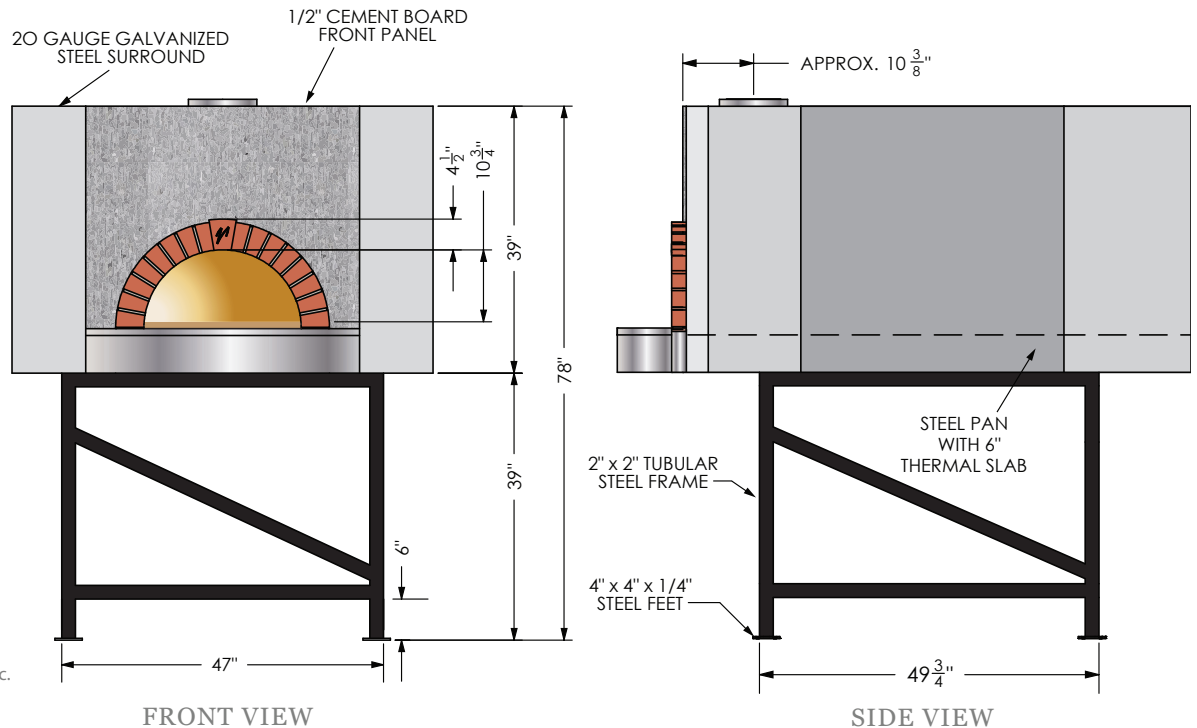
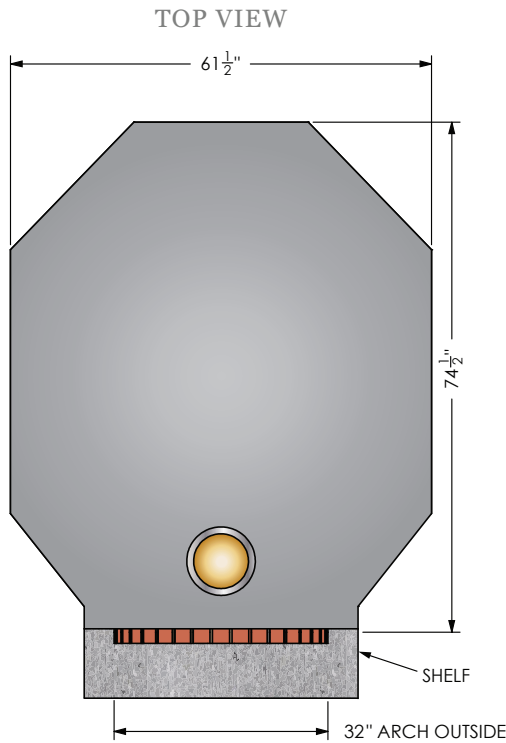

UL 2162 and UL 737



ANSI/NSF-4

© COPYRIGHT 2012, Mugnaini Imports, Inc.
 May not be used without permission of
 copyright holder.

Mugnaini Imports, Inc. • 1530 Grove Street, Healdsburg, CA 95448
 main: (707) 416-4106 • toll free: (888) 887-7206 • fax: (707) 857-7177
 mugnaini.com • mugnaini@mugnaini.com