

# MUGNAINI

— SINCE 1989 —

## Mugnaini Series

MODEL: 100 PA

**BUILT-IN ENCLOSURE**

COMMERCIAL WOOD FIRED OVEN

### CLEARANCES:

Install the oven with a minimum 1 inch clearance on sides and back to combustible construction. Consult the manual for enclosure instructions.

### VENTING:

The oven can be vented in two methods:

1. Direct vent using 8 inch chimney pipe listed to UL 103 HT and installed per UL 737.
2. Indirect vent using a Type 1 hood system installed per UL 2162.

### SHELF:

Stainless steel shelf bolts to oven. Shelf to be covered with non-combustible material provided by installer.

**WEIGHT:** 2300 lb.

### UTILITIES:

No electricity or gas required.

### NOTE:

The oven should be installed in accordance with all relevant local and national codes and in a manner acceptable to the authority having jurisdiction.

Progressive changes in technology and product development may necessitate changes to specifications without notice.

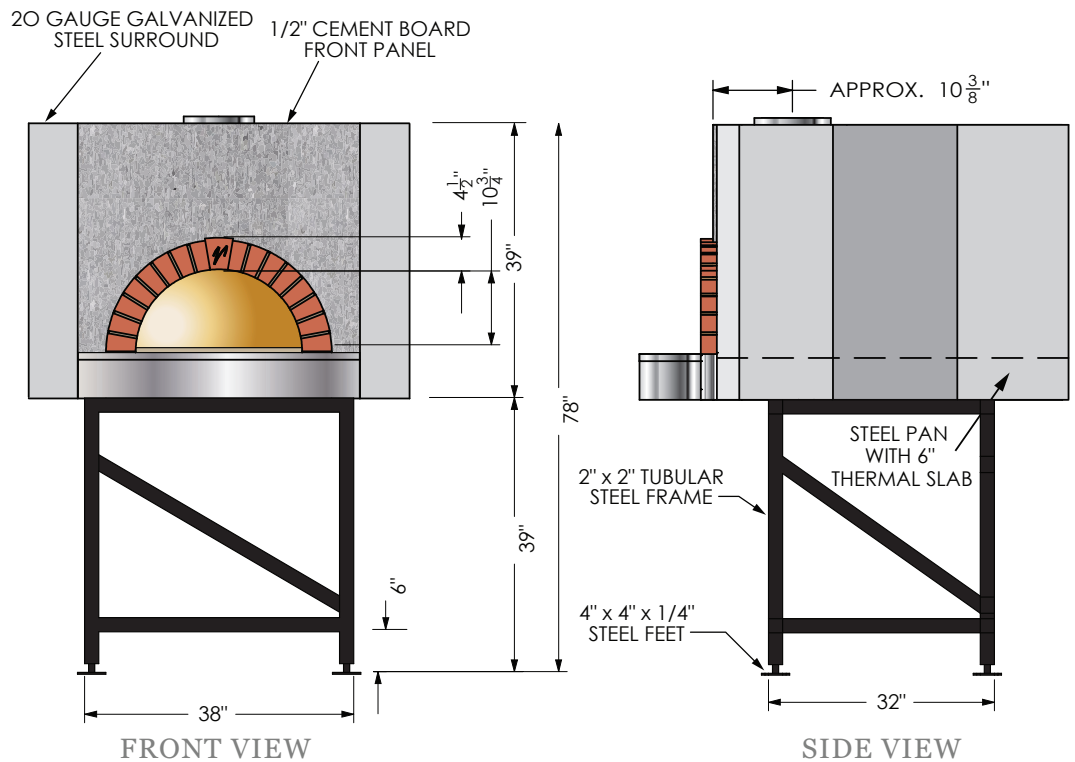
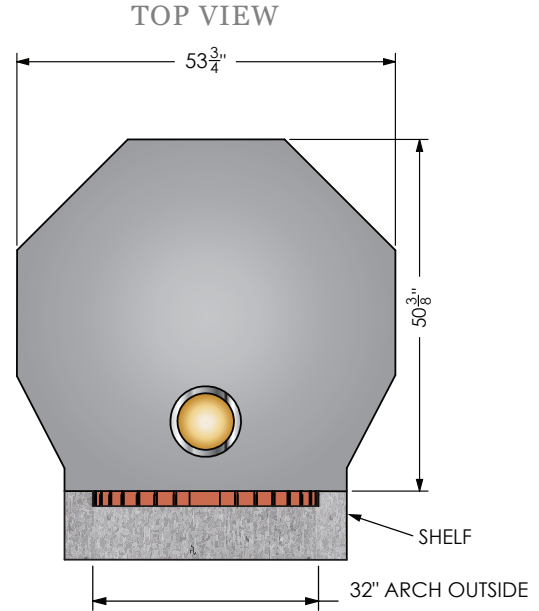

UL 2162 and UL 737



ANSI/NSF-4

© COPYRIGHT 2012, Mugnaini Imports, Inc. May not be used without permission of copyright holder.

Mugnaini Imports, Inc. • 1530 Grove Street, Healdsburg, CA 95448  
 main: (707) 416-4106 • toll free: (888) 887-7206 • fax: (707) 857-7177  
 mugnaini.com • mugnaini@mugnaini.com