

CLEARANCES:

Install the oven with a minimum 1 inch clearance on sides and back to combustible construction.

VENTING:

Direct vent using 8 inch chimney pipe listed to UL 103 HT and installed per UL 737.

SHELF:

Stainless steel shelf bolts to oven. Shelf to be covered with non-combustible material provided by installer.

WEIGHT: 4800 lb.

UTILITIES:

No electricity or gas required.

NOTE:

The oven should be installed in accordance with all relevant local and national codes and in a manner acceptable to the authority having jurisdiction.

Progressive changes in technology and product development may necessitate changes to specifications without notice.

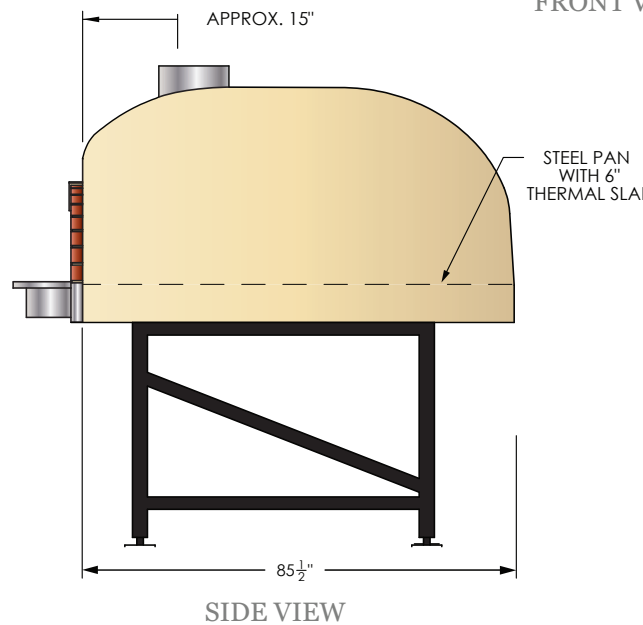
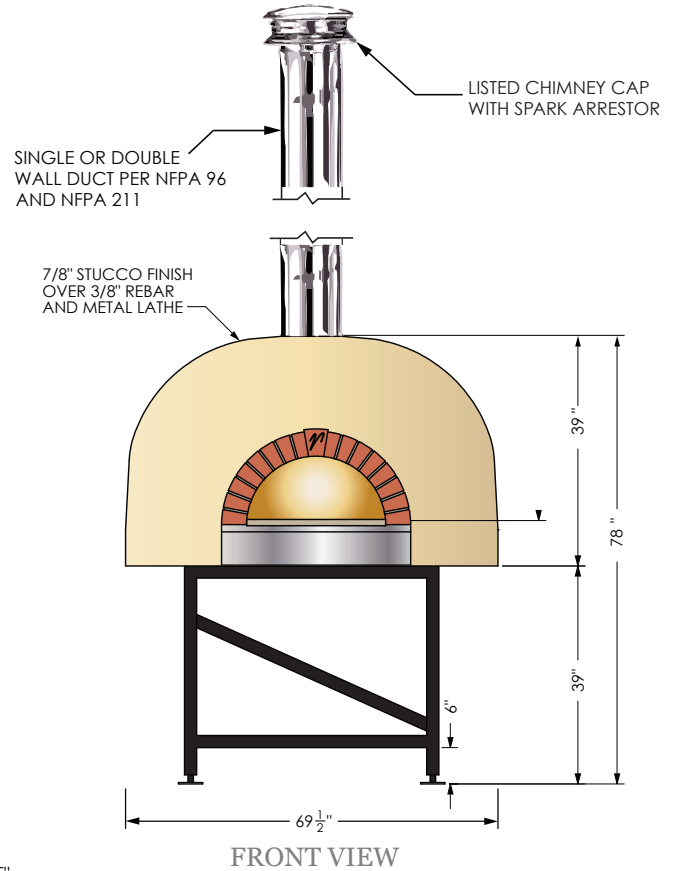

© COPYRIGHT 2013, Mugnaini Imports, Inc. May not be used without permission of copyright holder.



Mugnaini Imports, Inc.

11 Hangar Way, Watsonville CA 95076

888.887.7206 | 831.761.1767 | Fax: 831.728.5570

www.mugnaini.com | mugnaini@mugnaini.com