

## MOBILE OVEN AND TRAILER MOUNT

### MODEL: 120 COMMERCIAL WOOD-FIRED OVEN

#### FEATURES AND BENEFITS:

- Commercial 120 model oven with 48" round deck
- Oven is mounted to trailer and may be detached from trailer if necessary
- Fast start up with excellent heat retention
- Removable chimney stack and cap included
- Removable locking oven door included
- Four storage compartments
- Double swing-out doors in rear and front
- Polished stainless steel T-handles on doors
- Tandem 3,500 lbs. axels
- Electronic brake system
- Screw jacks in front/stabilizer jacks in rear
- Receiver tube in rear of trailer for directional parking
- 1' wide x 72" long tear drop steel fenders
- Aluminum diamond plate 9" x 36" in center of fenders
- 15" chrome mod rims/load rated trailer tires, 1760 lbs. each
- Adjustable 2-5/16" - 10,000 lbs. coupler with safety chain snap hooks
- 3/4" plywood floor - epoxy coated (interior)
- Auto grade paint (color - customer's choice)
- Rubber mounted seal beam lights
- Certified weight certificate for DMV

#### WEIGHT:

Approximately 4,300 lbs. trailer and oven combined

#### NOTE:

Progressive changes in technology and product development may necessitate changes to specifications without notice.

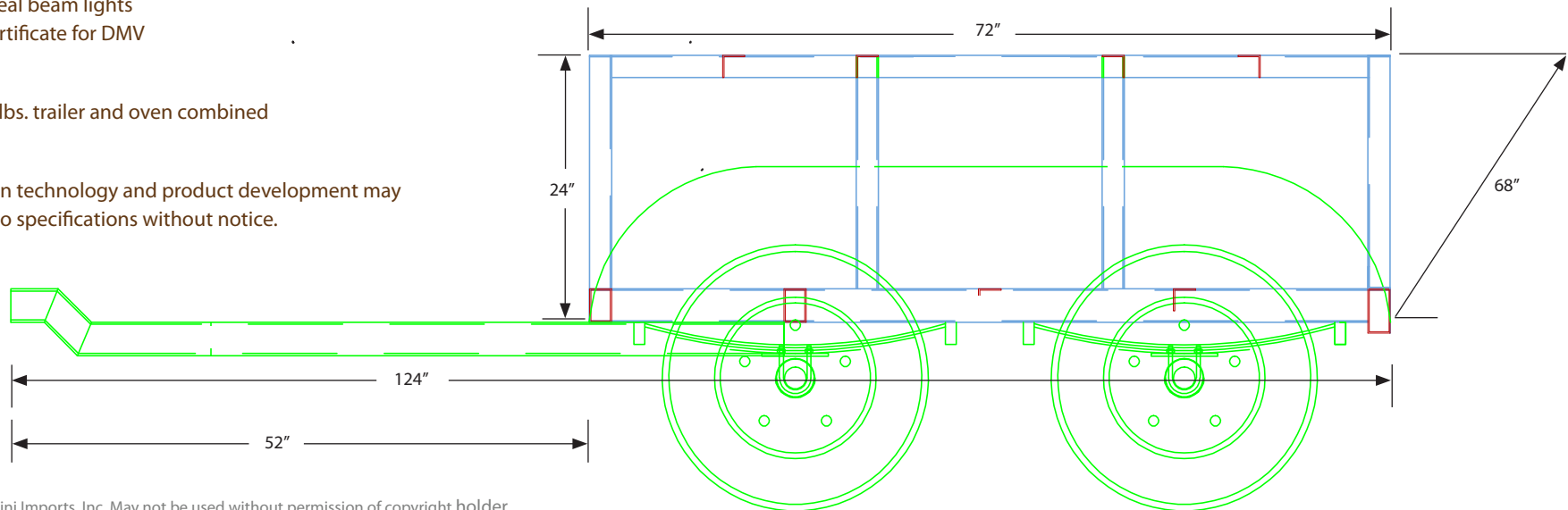
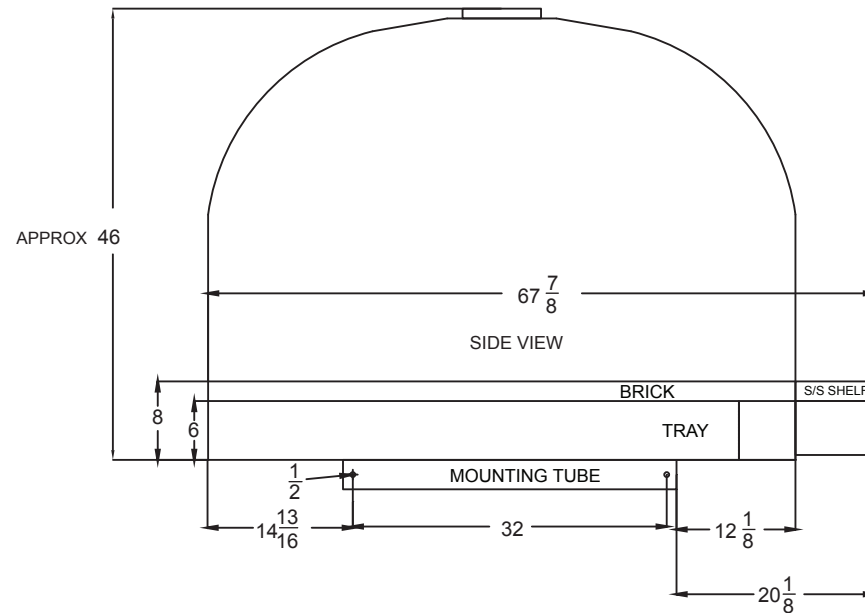

© COPYRIGHT 2012, Mugnaini Imports, Inc. May not be used without permission of copyright holder.